

ITEM	PART NO.	DESCRIPTION	QTY	NOTES
1	020-4604	SPACER, 1/2 ID X 3/4 OD X .31L	1	
2	110-0477	BOLT, 1/4-20 X .75", BHCS	12	
3	110-0711	BOLT, SHOULDER, 1/2" DIA X 1/2 LG	1	
4	110-1823	NUT, JAM, 1/2-13 x 5/16 THK	2	
5	120-0420	WASHER, 1/4, SPLIT LOCK	12	
6	120-3029	WASHER, 1/2 ID X 1.25 OD, NEOPRENE	1	
7	120-3030	WASHER, 1/2 ID X 1.0625 OD X .093 THK	2	
8	130-0050	BELT, HTD 1595-5M15	1	
9	130-0250	PULLEY, 28-5M-15M15	1	
10	140-3200	FEET, 1/2-13 SCREW, 3.0" BASE	2	
11	260-0235	MOTOR, GEAR ELEV 3K PWM	4	REF
12	708-0430	IDLER ASSY, ELEV	1	
13	710-1055	FRAME, FINISHED, NO LOAD CELL, PRO TR	4	REF
14	715-3364	SUB ASSY, ELEV, PRO TR	1	

REVISIONS				
REV.	DATE	DESCRIPTION	ECO #	CHG BY
X1	02-18-04	PROTOTYPE RELEASE	—	N/A
A	06-04-04	PRODUCTION RELEASE	11137	FJM
B	09-19-07	UPDATE DIMENSION. WAS 3.75. IS 3.75±0.060 UPDATE TENSION. WAS 55±5. IS 60±5	11724	ME

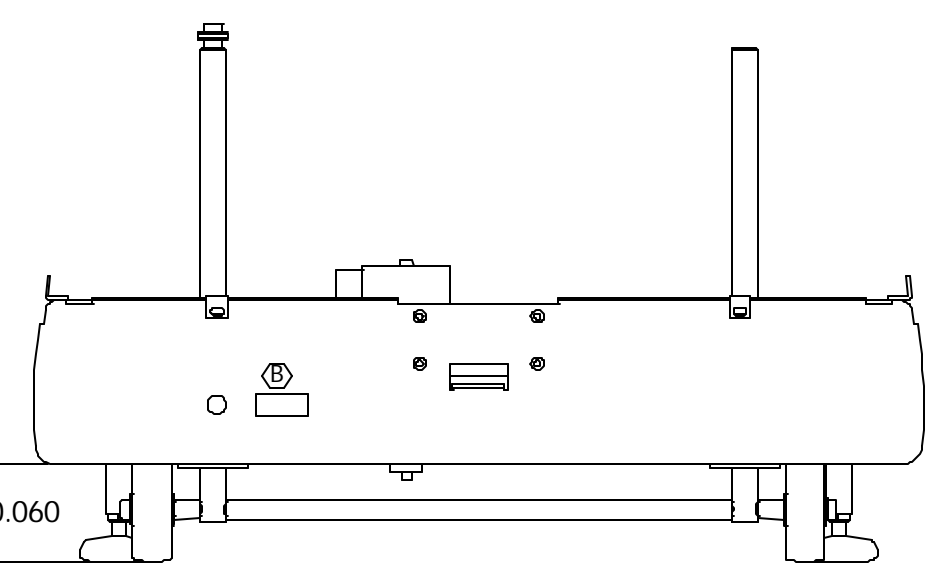
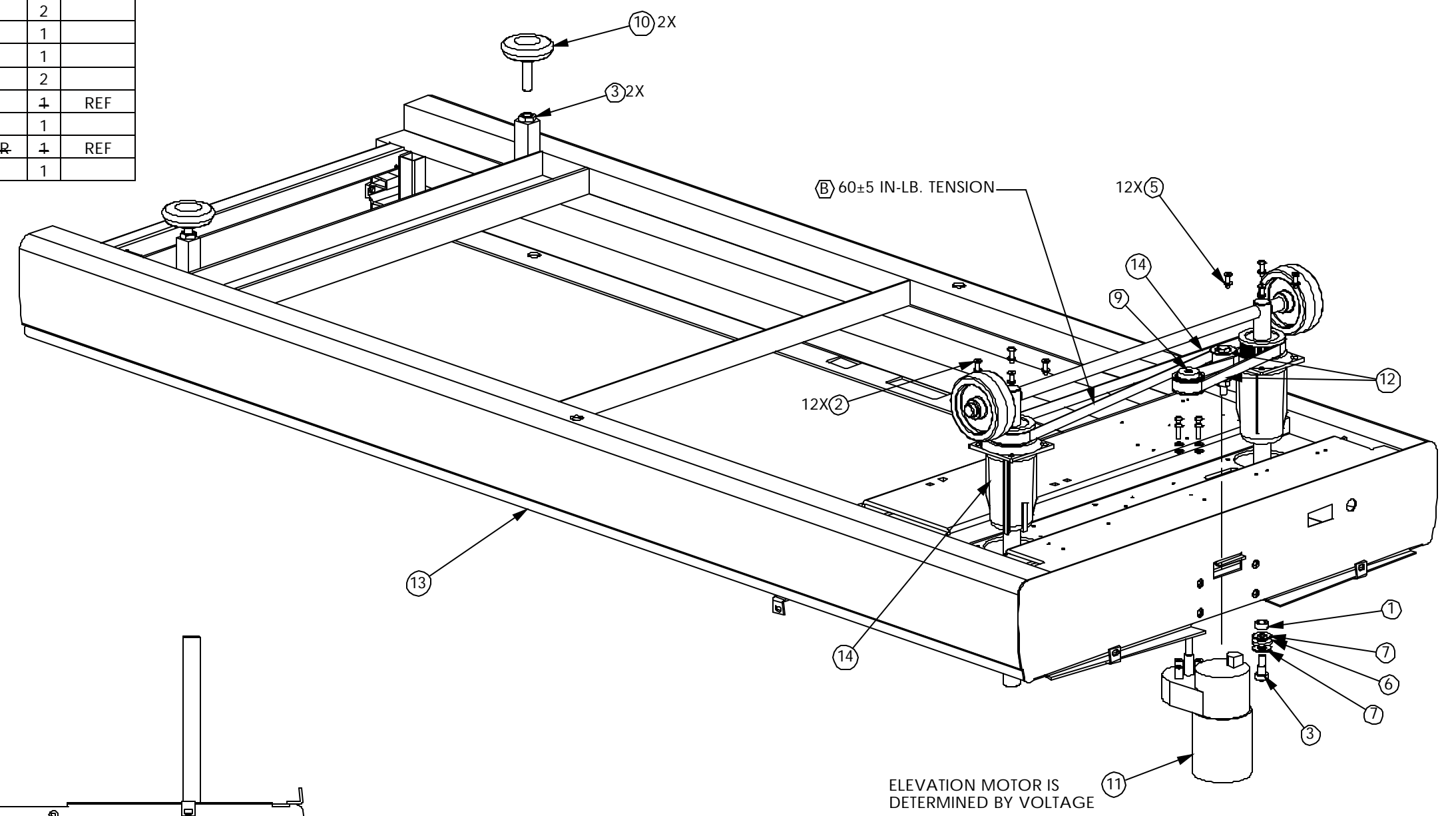

NOTES:
 ⓑ 3.75 ± 0.060
 0.060 = 1 REVOLUTION TURN ON FOOT SCREW

**DOCUMENT STATUS:
RELEASE**

NOTICE OF PROPRIETARY INFORMATION
 THIS DOCUMENT SHALL NOT BE REPRODUCED NOR
 SHALL THE INFORMATION CONTAINED HEREIN BE
 USED BY OR DISCLOSED TO OTHERS EXCEPT AS
 EXPRESSLY AUTHORIZED BY UNISEN

MATERIAL	TOLERANCES UNLESS OTHERWISE SPECIFIED		UNISEN INC. 14410 Myford Road Irvine, CA 92606	
REFER TO BOM	.XXX=+/-	ANGLES=+/-	B ASSY, ELEV PLATFORM, PRO REV	
	.XX =+/-	FRACTION=+/-		
FINISH	DRAWN	INITIAL	DATE	SCALE 1:1
N/A		FJM	02-18-04	SIZE B
	CHECKED			PART #
	APPROVED			715-3585
	U.O.M.	INCH		SHEET 1 OF 1